

INJECTION BLOW MOLDING WITH FDM

Time Required ■■■

Cost ■■■

Skill Level ■■■

By Susan Sciortino, Stratasys Inc.

OVERVIEW

Blow molding is a manufacturing process in which air pressure inflates heated plastic in a mold cavity. It is used for the production of hollow plastic parts with thin walls, such as beverage bottles (Figure 1), cosmetic containers and pharmaceutical packaging.

There are three types of blow molding: extrusion, injection and stretch. In extrusion blow molding, a molten tube of plastic is extruded into a mold cavity and inflated with compressed air. Injection blow molding is a two-step process (Figure 2). A contoured preform is injection molded and then transferred to a blow mold cavity where it is inflated. Stretch blow molding uses the same procedures as injection blow molding, but prior to inflation, a ram stretches the pre-form. The stretching aligns the polymer chains, creating stronger parts with better clarity and gas barrier properties. There are two methods of stretch blow molding, ISBM (injection stretch blow molding) and RHB (reheat and blow). With ISBM, the injection molded preform is immediately transferred to the blow molding tool. RHB uses pre-forms that are injection molded and inventoried. The preform is then reheated and blow molded.

Many thermoplastics, including polystyrene, PC and polyvinylchloride (PVC), can be blow molded. However, the most common resins are high-density polyethylene (HDPE), low-density polyethylene (LDPE) and polyethylene terephthalate (PET).

The design of blow molds and the specification of process parameters combine science, art and skill. A small change in vent design, die temperature or blow pressure can dramatically affect the molding results. To validate these parameters and accelerate design approval, prototype tooling is needed. However, machined prototype tooling is both costly and time consuming.

To reduce lead time and expense, blow molders are now adopting FDM. In five days or less, companies can design a mold, build the tool and blow mold near-production quality prototypes.

This process guide provides information on the application of FDM to injection blow molding. When producing prototype injection blow molded parts, combine these general guidelines with existing practices, procedures and preferences.

FDM AND INJECTION BLOW MOLDING

When a Fortus 3D Production System is used to construct blow molds, the lead time for prototype parts is reduced from weeks to less than five days. In addition, the cost for prototype tooling is significantly less than that of machined tools. In most cases, the FDM tooling will cost one-third to one-half that of a prototype aluminum tool. Additionally, FDM is an excellent supplement to a busy CNC and blow molding equipment backlog.

The FDM process is unique in its use of thermoplastics, and it is this attribute that provides the benefits of rapid tooling for blow molding. Fortus PC can withstand both the temperature and pressure of blow molding (figure 3). With no wear or deformation, an FDM tool can produce hundreds, even thousands, of molded parts in materials like HDPE, LDPE, PET, PVC, PC, polystyrene, and polyethylene.

As this guide illustrates, injection blow molding with FDM tooling requires only minor modifications to standard mold design and molding parameters. So, any prototype blow molding project can use FDM tools little change to conventional practices and processing standards. With FDM blow molds, prototype bottles and containers are produced quickly and affordably. The near-production quality of the molded parts expedites product and process analysis and customer design approval.

APPLICATION BRIEFS

Prototype Beverage Bottles

A container manufacturer challenged Stratasys to reduce both cost and time for the development of blow molded prototypes. The goal was to decrease the time for prototyping near-production



Figure 1: Blow molding is widely used for hollow plastic parts such as this beverage bottle

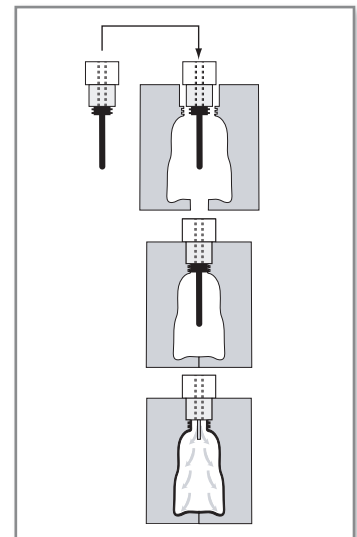

Figure 2: A preform is injection molded and placed in the blow mold. The preform is then inflated.



Figure 3: Blow mold constructed from the FDM process.

quality parts from several weeks to less than five days. The company selected a six-inch tall, 3-inch diameter (152 x 76 mm) bottle for the pilot project. Using Fortus PC material for the tool cavity and a machined aluminum mold base, the blow mold was designed and built in only two days. With only minor changes to the tool design and molding process, the bottle was blow molded in BP Solvay Fortiflex® HP 58, an HDPE. This can be changed to include the smaller dimensions of the Swirl bottle (which is approximately 5" tall, 2 1/2" diameter) and only with PET. The entire process was completed in less than five days, and the company stated that the molded prototypes met their criteria for near-production quality.

Tool Life Analysis

Using Fortus PC tooling, one manufacturer successfully blow molded 800 bottles in PET. Due to time constraints, and the desired quantity of prototypes, the testing was stopped after molding 12 pieces. Inspection revealed that there was no wear, distortion or dimensional change to the FDM tool. The company concluded that an FDM blow mold could produce thousands of parts, if desired.

PROCESS OVERVIEW

Injection blow molding offers superior visual and dimensional quality when compared to extrusion blow molding. The process also supports thermoplastics that cannot be extruded. However, injection blow molding is limited to small containers that are less than six ounces, and it cannot produce handleware.

In the first stage of the process, a preform is injection molded (figure 4). A blow pin is inserted into the tool and molten plastic is injected into the mold cavity. The plastic surrounds and captures the blow pin. While still semi-molten, the preform is transferred to the blow mold. Once transferred, it is called a parison.

The advantages of injection blow molding are derived from this first stage. With injection molding of the preform, the parison size and shape is precisely controlled, which allows the blow molded part to have varying wall thickness (figure 5). The molded preform also supports thick wall sections, as found in bottle threads, since they fully formed during the injection molding stage.

In the second stage, compressed air, typically 85 to 120 psi (586 to 827 kPa), inflates the parison (figure 6). The air pressure forces the plastic against the mold surface causing it to take the shape of the mold cavity. The molded part is then cooled and ejected.

PROCESS

A Fortus PC tool, or tooling insert, replaces a machined blow mold, which is commonly made from aluminum, tool steel, stainless steel or beryllium copper. For prototype injection blow molding, the FDM tool eliminates the labor and expense and decreases the time needed to machine metal tools.

Although FDM has been used for injection molding applications, tooling for the molding of the preform is commonly machined. Since the preform is a small, simple shape, the injection mold is easily machined. Replacing aluminum tooling with FDM offers only marginal gains in time and cost. However, if FDM is a desirable alternative, contact a Stratasys representative for guidance on injection molding.

TOOL DESIGN

With the exception of venting and shut-offs, the FDM tool's design is similar to any machined blow mold. In an FDM tool, vents are not added. Since the FDM cavity has a small amount of porosity, air trapped between the molded plastic and tool surface is vented through the body of the tool.

To minimize flash, a sloped, raised rib is added around the contour of the cavity. This rib acts as a compression seal between the mold halves, which gives clean shut-off. In testing, a 0.125 in. wide (3.2 mm) rib that is 0.060 in. high (1.5 mm), has performed well when blow molding HDPE. The rib has a sloped outer edge, as shown in figure 7. These specifications may vary with part size, plastic selection and molding parameters. Therefore, adjustments may be needed.

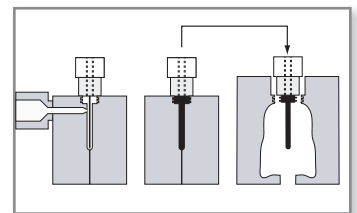

Figure 4: Preform is injection molded and transferred to the blow molding tool.

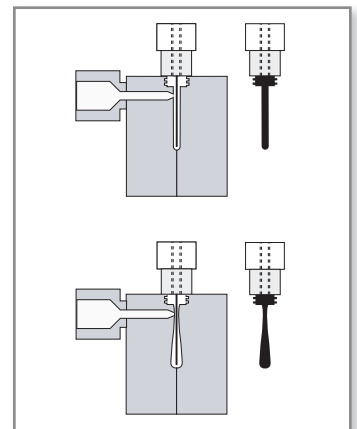

Figure 5: Varying the shape of the preform offers variable wall thickness.

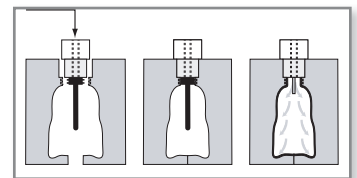

Figure 6: After the preform is molded, it is transferred to the blow mold tool and inflated.

There are three tool design options. Selection of the best option balances the blow molding machines specifications, the needs of the molded part and personal preferences.

1. **FDM Tool:** The entire tool is constructed with FDM (figure 8).
2. **Hybrid Tool - Block Insert:** A rectangular FDM insert is paired with a pre-fabricated aluminum mold base.
3. **Hybrid Tool - Contoured Insert:** An FDM insert that follows the contours of the molded part is paired with a pre-fabricated aluminum mold base (figure 9).

To date, only FDM tools have been used with injection blow molding. However, due to the success of the hybrid options with extrusion blow molding and the similarity of process demands, the hybrid tooling options should prove suitable for injection blow molding.

FDM TOOL DESIGN

With the exception of venting and the addition of the perimeter rib, the tool is designed like any machined mold. Cooling channels may be constructed in the FDM tool, but it is simpler and faster to use a standard mounting plate with cooling lines.

Hybrid Tool - Block Insert Design:

Allow 0.5 in. (12.7 mm), at a minimum, around the periphery of the mold cavity. For example, a three-inch tall, one-inch diameter (76.2 x 25.4 mm) bottle would have two rectangular mold halves that measure 4 x 2 x 1 in. (101.6 x 50.8 x 25.4 mm).

Mount the FDM inserts in a machined aluminum mold base that has a rectangular cavity with the same dimensions as the insert. To minimize the cost and time needed to make the mold bases, establish an inventory of standard sizes and design the FDM insert to fit within one of these standards.

Note that this design option may result in stress fractures. The aluminum mold base restrains the PC insert as it expands during blow molding. To avoid fractures, increase the duration of the cooling cycle.

Hybrid Tool - Contoured Insert Design:

For the face of the insert, allow 0.5 in. (12.7 mm), at a minimum, around the periphery of the mold cavity. Unlike the rectangular insert, each FDM insert will have a contoured back side. Following the contours of the molding surface, create a surface that is offset by at least 0.5 in. (12.7 mm).

This tooling option offers the advantages of reduced material consumption and build time. It also reduces molding cycle time because the insert retains less heat.

As with the rectangular inserts, make aluminum mold bases that are appropriate for the standard sizes of molded parts. These mold bases will have a rectangular cavity that holds the FDM insert. Since the insert is contoured, there will be an air gap between the back side of the FDM insert and the aluminum cavity.

COOLING SYSTEM

For the hybrid tools, use normal cooling channel design and incorporate the cooling system in the aluminum mold base. As stated previously, tools made entirely from FDM may have the cooling system in the PC tool or the mounting plate. To reduce cycle times, cooling lines should be supplemented with compressed air blown onto the face of the tool after ejection of the molded part.

Although no design specifications are available, research on flood cooling is ongoing. To minimize cycle times, FDM tools or inserts are made hollow and coolant floods the internal chamber.

TOOL CONSTRUCTION

Orient the mold cavities such that the mold face (parting surface) is perpendicular to the Z-axis. Although the vertical orientation will add time to the build, it provides the best surface characteristics for the mold cavity and will yield the best shut off between the mold halves. The FDM molds are constructed using normal build parameters with the exception of using

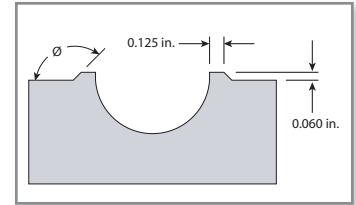

Figure 7: A rib is added to the tool design. The rib follows the contours of the mold cavity.



Figure 8: FDM blow molding tool made from polycarbonate.



Figure 9: FDM hybrid tool with contoured inserts

multiple contour paths along the cavity walls (figure 10). Increasing the number of contours paths diminishes porosity in the mold to produce a better part.

Note that ABS and polyphenolsulfone (PPSU/PPSF) are not suitable for blow mold tooling. ABS does not have the properties to withstand the temperature and pressure of blow molding. Although PPSU/PPSF is strong and heat resistance, it retains too much heat, which causes blow molded parts to stick to the tool. For these reasons, use only PC for injection and extrusion blow molding.

After building the FDM tool, remove all support structures and bead blast the cavity with plastic blast media. This simple and quick two-step process will produce a tooling surface that molds near-production quality parts.

Prior to bead blasting the tool, mask off the parting surface and any sharp corners. Then place the tool in a bead blaster—loaded with plastic blast media—and spray the cavity of the tool using a pressure of 60 to 90 psi (414 to 621 kPa). Bead blasting eliminates all labor for sanding and filling while protecting dimensional accuracy. For additional processing information, refer to Bead Blasting Finishing Guide. The faces of the tools will not need any machining or hand work. The untouched surface provides good shut-off and minimal flash.

The final step is to mount the FDM insert in a pre-fabricated aluminum mold base. The tool is now ready for blow molding.

BLOW MOLDING

Prototype blow molding requires only one change to the process. Since the PC cavities will retain heat, the cooling cycle is extended. The duration will vary by tool, part and molded plastic, so the cycle time is determined through experience and trial-and-error.

Start with a cooling cycle that is five times longer than that for a metal blow mold. If molding is successful, decrease the duration and repeat. Continue to decrease the cycle time until the molded part begins to stick. Return to the last successful molding cycle and begin blow molding the prototype parts.

Even though the cooling cycle is lengthened, the temperature will increase with each cycle, and molded parts will begin to stick to the tool. When this happens, open the tool and allow it to return to operating temperature. Optionally, compressed air can be blown on the tool to accelerate the cooling process.

Following the cooling cycle, the blow molded part is ejected. The prototype parts are now complete and ready for review (figure 11).

CONCLUSION

Using these process guidelines, FDM can be incorporated into the prototype injection blow molding process. Replacing machined metal tools with FDM molds addresses two barriers to prototype development—time and cost. Delivery of molded prototypes is slashed by 50 to 75 percent and the cost of the prototype tooling is reduced by 50 to 60 percent.

Since FDM tooling replaces conventional tooling with only minor design and process changes, this prototyping technique can be used in any blow molding operation.

Near-production quality and a broad selection of molding plastics make FDM an ideal choice the production of prototype blow molded parts. Both quick and affordable, FDM expedites product and process analysis and customer design approval.

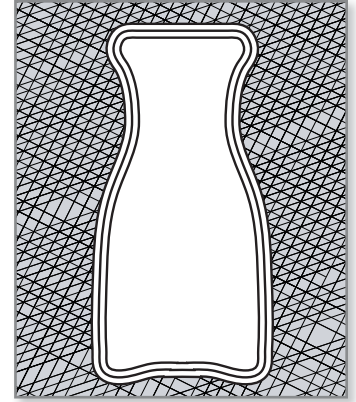

Figure 10: Increasing the number of contour passes reduces porosity and improves part quality.



Figure 11: Near-production quality prototype bottle molded in PET.

FDM PROCESS DESCRIPTION

Fortus 3D Production Systems are based on patented Stratasys FDM (Fused Deposition Modeling) technology. FDM is the industry's leading Additive Fabrication technology, and the only one that uses production grade thermoplastic materials to build the most durable parts direct from 3D data. Fortus systems use the widest range of advanced materials and mechanical properties so your parts can endure high heat, caustic chemicals, sterilization, high impact applications.

The FDM process dispenses two materials—one material to build the part and another material for a disposable support structure. The material is supplied from a roll of plastic filament on a spool. To produce a part, the filament is fed into an extrusion head and heated to a semi-liquid state. The head then extrudes the material and deposits it in layers as fine as 0.005 inch (0.127 mm) thick.

Unlike some Additive Fabrication processes, Fortus systems with FDM technology require no special facilities or ventilation and involve no harmful chemicals and by-products.

For more information about Fortus systems, materials and applications, call **888.480.3548** or visit www.fortus.com

Fortus 3D Production Systems
Stratasys Incorporated
 7665 Commerce Way
 Eden Prairie, MN 55344
 +1 888 480 3548 (US Toll Free)
 +1 952 937 3000
 +1 952 937 0070 (Fax)
www.stratasys.com
info@stratasys.com

Fortus 3D Production Systems
Stratasys GmbH
 Weismüllerstrasse 27
 60314 Frankfurt am Main
 Germany
 +49 69 420 9943 0 (Tel)
 +49 69 420 9943 33 (Fax)
www.stratasys.com
europe@stratasys.com